

Type 6501 & 6502 expansion joints are available with full thrust anchor bases.

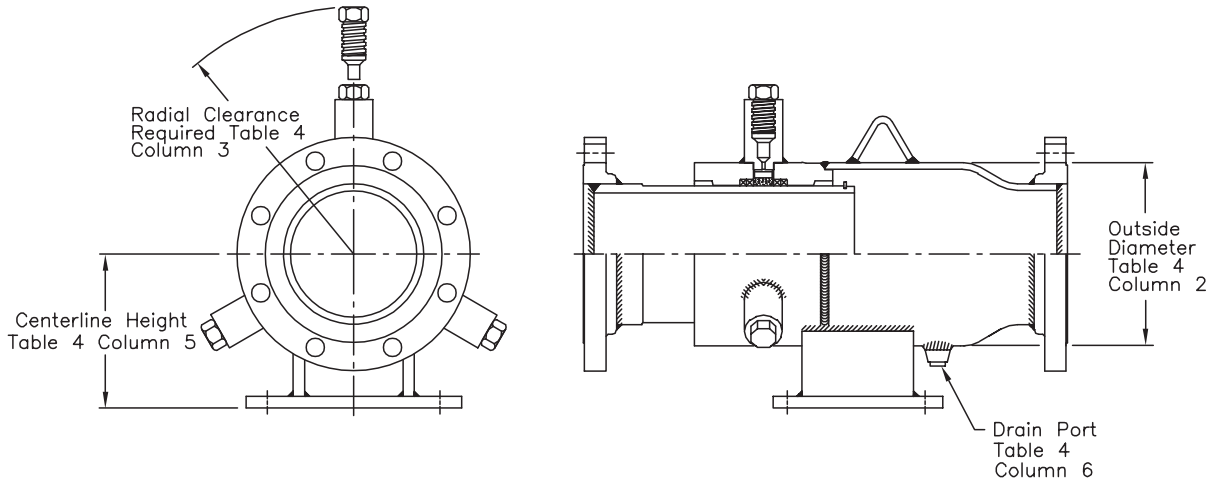

Anchor Base drilling dimensions. Refer to Columns 7–11 of Table 4 for details.

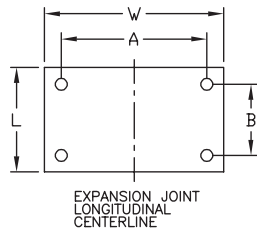

Injector Fitting orientation

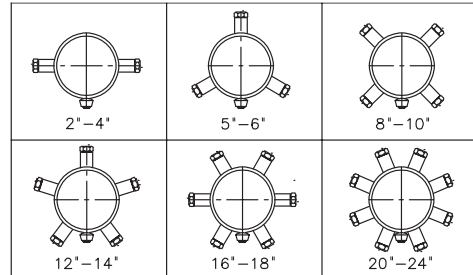

Ordering Instructions

Refer to Tables 5 through 8 to select the configuration and service conditions required for your application. If the travel required is unknown see the method of calculation on Page 5.

Example

2" NPS
Single Expansion Joint
Steel pipe weld ends
150 psig at 500°F maximum
4.0" axial travel maximum

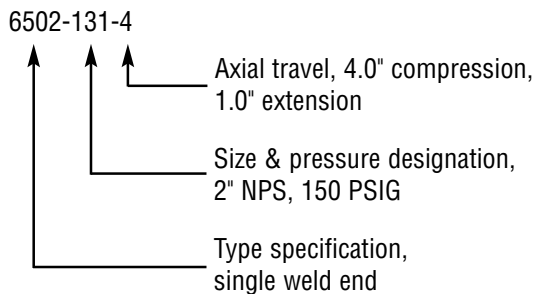

Single expansion joints, 6501 and 6502, ordered with anchor based are identified as 6501AB and 6502AB. Anchor bases are standard on dual anchor base joints, 6505 and 6506, and do not require the AB suffix.

Optional features must be specified by a written description accompanying the part number. Options that are available include:

- Higher rated pressure and temperature
- Vent or instrumentation ports
- Service outlets (size and orientation must be specified)
- 1/4 Turn valve on each injector fitting
- Alternate materials
- Factory preset of overall length
- Grooved end attachments
- Threaded adjusting rods for field preset