

UNIVERSAL EXPANSION JOINT, CONTINUED

As a direct result of increasingly high operating pressures and temperatures, and lighter building construction methods, universal Expansion Joints are finding increasing use in steam and hot water distribution systems where, due to their ability to absorb large amounts of movement with minimum guiding and anchoring, they offer impressive savings in overall cost.

FIGURE D

APPLICATIONS FOR ANGULAR MOVEMENT

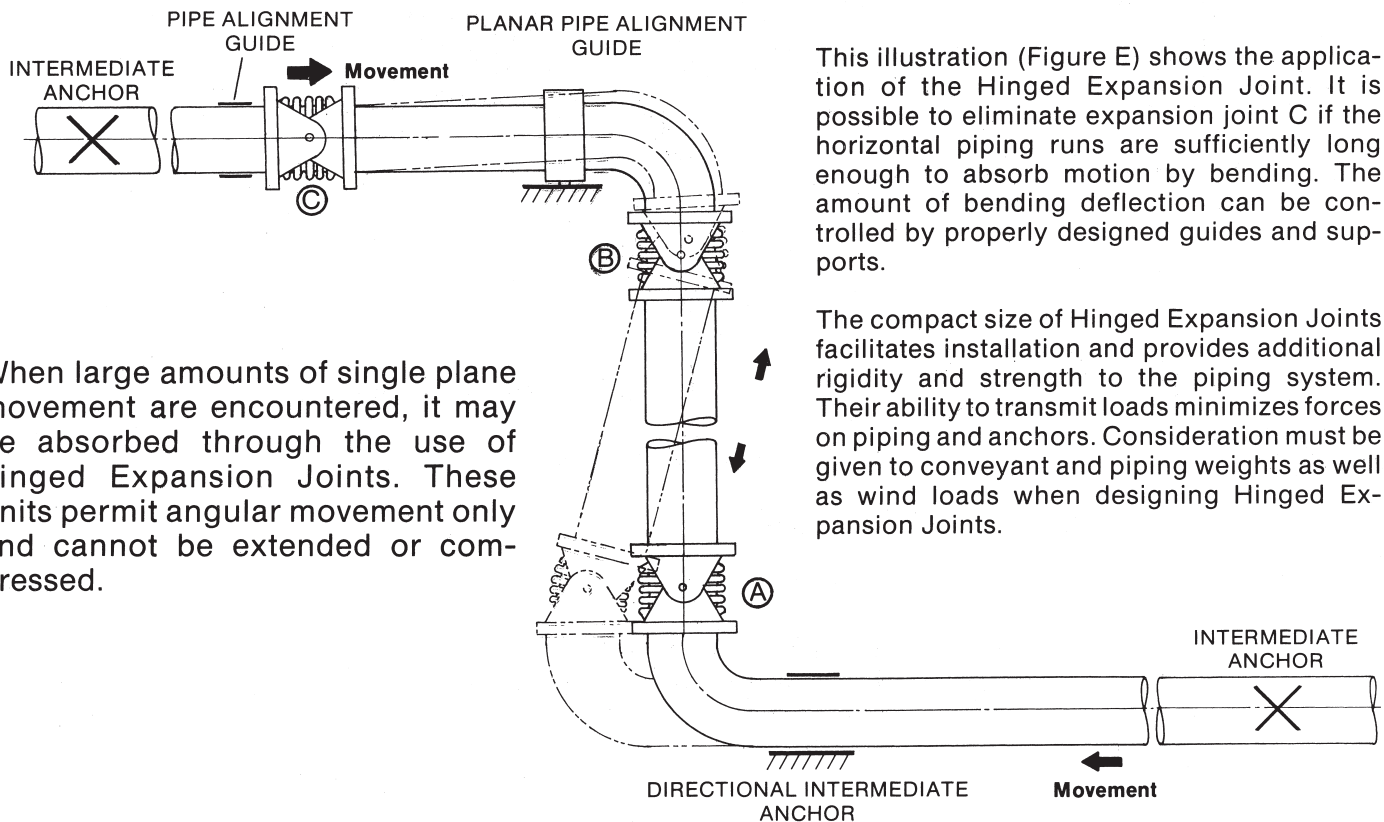

When large amounts of single plane movement are encountered, it may be absorbed through the use of hinged Expansion Joints. These units permit angular movement only and cannot be extended or compressed.

This illustration (Figure E) shows the application of the Hinged Expansion Joint. It is possible to eliminate expansion joint C if the horizontal piping runs are sufficiently long enough to absorb motion by bending. The amount of bending deflection can be controlled by properly designed guides and supports.

The compact size of Hinged Expansion Joints facilitates installation and provides additional rigidity and strength to the piping system. Their ability to transmit loads minimizes forces on piping and anchors. Consideration must be given to conveyant and piping weights as well as wind loads when designing Hinged Expansion Joints.

FIGURE E