



# Hyspan<sup>®</sup>



**Series 3500**

**Externally Pressurized Expansion Joints**

Catalog 574H

## Series 3500 Externally Pressurized Expansion Joints



- Standard Designs Sizes 2" through 24", 150 & 300 PSIG at 500°F
- Axial Travel of 4", 6" & 8" for Single Configurations 8", 12" & 16" for Dual Anchor Base Configurations
- Maximum Flexibility and Extended Life
- Low Spring Forces and Pressure Thrust
- Standard In-Line Pressure Balanced Configurations

Since the externally pressured expansion joint design was introduced to the piping

industry in 1972 by Hyspan, it has become a standard in piping system design. This configuration has a totally enclosed bellows that is protected from the flow on the interior, and the environment on the exterior by standard weight pipe. Since the media is on the exterior of the bellows it is self draining, and bellows instability or squirm is not a consideration. Rigid guides on the interior and exterior ensure alignment of the bellows.

The proven design of Hyspan Series 3500 Externally Pressurized Expansion Joints excels because of close attention to detail design and high quality workmanship. *Since 1982 Hyspan has offered a full five year replacement warranty (Page 15) on the standard design expansion joints. These designs offer an affordable product with a proven service record without the use of expensive high nickel alloys.*

### Table of Contents

Design Features . . . . .	3	Table 5 Type 3501 & 3502 150 psig Design Data . . . . .	8
Applications . . . . .	3-4	Table 6 Type 3505 & 3506 150 psig Design Data . . . . .	9
In-Line Seismic Expansion Joint . . . . .	4	Table 7 Type 3501 & 3502 300 psig Design Data . . . . .	10
Travel Required . . . . .	5	Table 8 Type 3505 & 3506 300 psig Design Data . . . . .	11
Anchor Forces . . . . .	5	In-Line Pressure Balanced Expansion Joints . . . . .	12
Table 1 Thermal Expansion . . . . .	5	Table 9 3501PB & 3502PB 150 psig Design Data . . . . .	12
Table 2 Pressure and Force Data . . . . .	6	Table 10 3501PB & 3502PB 300 psig Design Data . . . . .	13
Table 3 Intermediate Pipe Guide Spacing . . . . .	6	Installation Procedure . . . . .	14-15
Materials of Construction & Dimensional Data . . . . .	7	Five Year Limited Warranty . . . . .	15
Table 4 Dimensional Data . . . . .	7		
Ordering Instructions . . . . .	7		

# Design Features

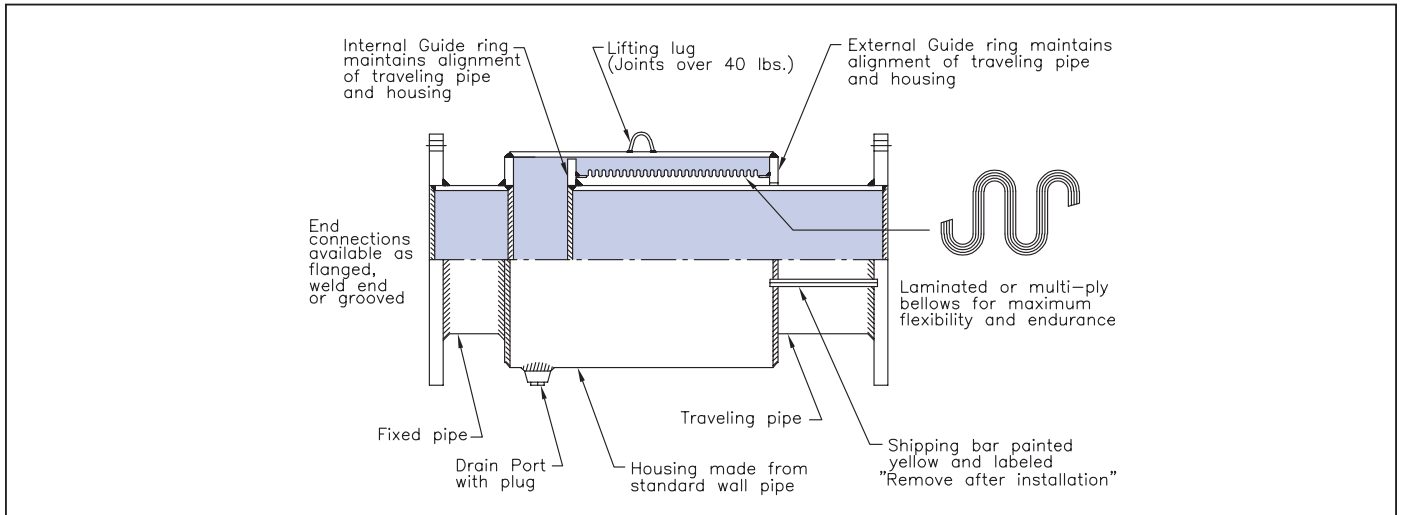

# Applications

Series 3500 expansion joints are designed for installations where the principal movement is axial. Standard single configurations are designed for 4", 6" and 8" of axial compression (pipe expansion) and 1", 2" and 2" extension respectively. Dual configurations are designed for 8", 12" and 16" of axial compression and 2", 4" and 4" extension respectively. If the primary movement is extension (pipe contraction) the expansion joint can be preset at the factory. The piping system must include anchors to react the force produced by pressure thrust and the bellows spring constant, supports to react the weight of the pipe and media, and guides to ensure that the pipe alignment is maintained.

## Single Expansion Joint, 3501 or 3502 Adjacent to Main Anchor

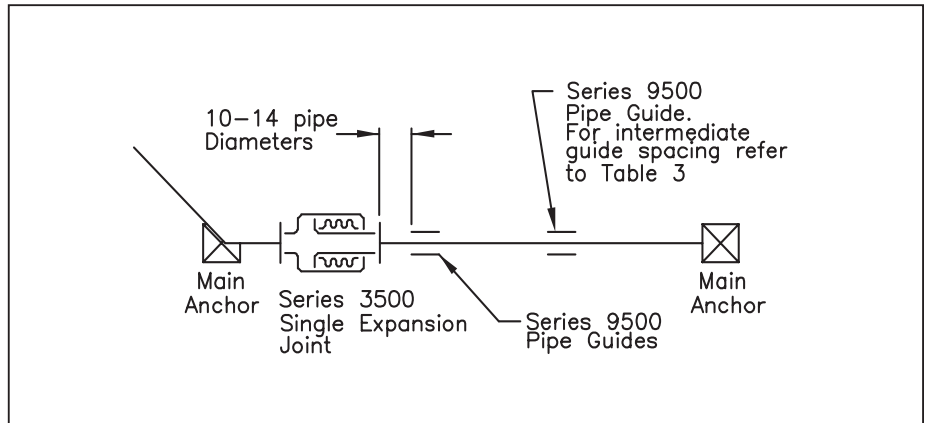

## Single Expansion Joint, 3501 or 3502 Located in the Middle of a Run

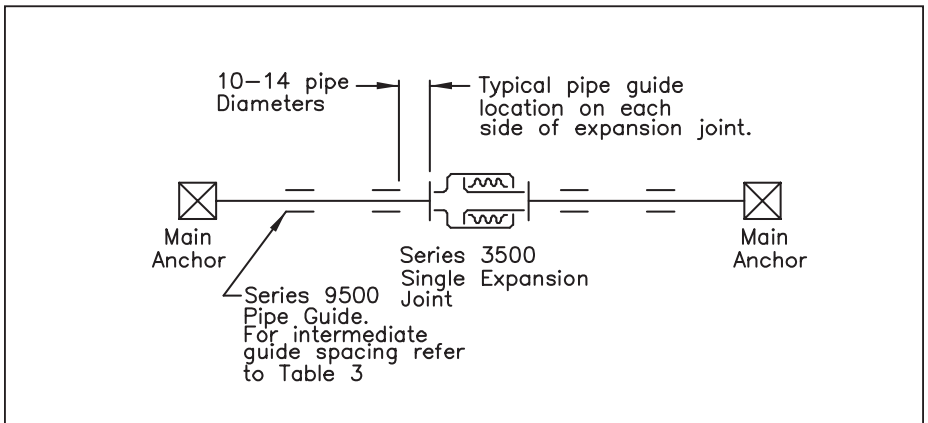

## Applications, Continued

### Two or More Single Expansion Joints 3501 or 3502 with Intermediate Anchors

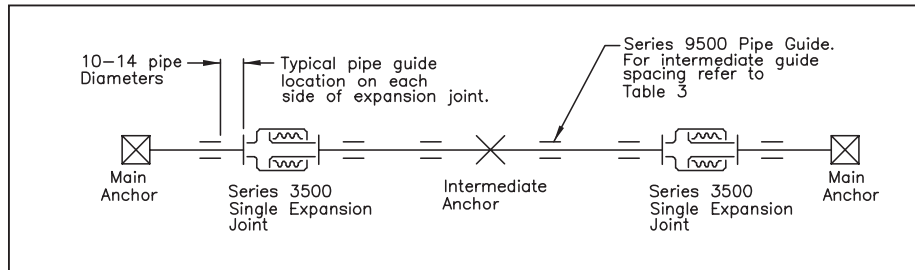

See page 5 for calculation methods for travel required and anchor forces.

See Table 3 for minimum recommended intermediate guide spacing to ensure that the pipe travel is translated to, and aligned with the expansion joint.

### Dual Anchor Base Expansion Joint 3505 or 3506 Located in the Center of a Run

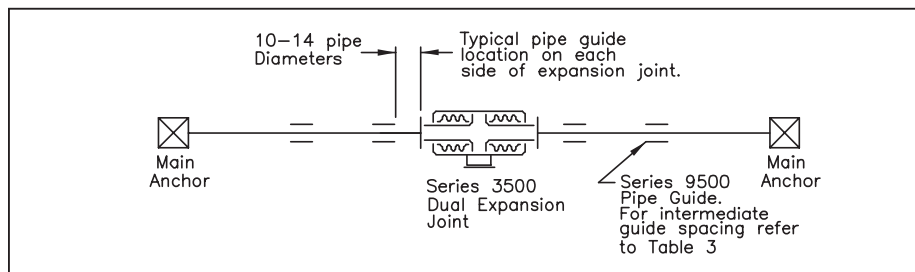

Series 9500 Pipe Guide see Catalog 1004 for details.

### In-Line Pressure Balanced Expansion Joint 3501PB or 3502PB with Intermediate Anchors

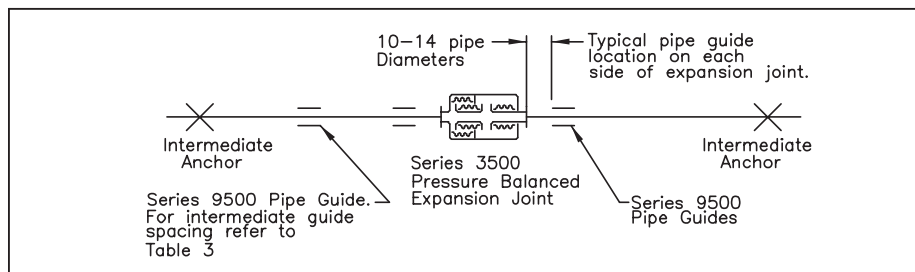

### In-Line Seismic Expansion Joint 3500IS

Hyspan Series 3500 expansion joints are combined with Hyspan Barco ball joints to create an in-line rugged maintenance free product that can be used for seismic

connections, tank and building settling, and pipe line settling in unstable soil. Standard designs 2"-12" for 24" axial extension or compression combined

with 24" offset from centerline in any direction. Refer to catalog material for 3500IS for complete details. Horizontal or vertical installations.

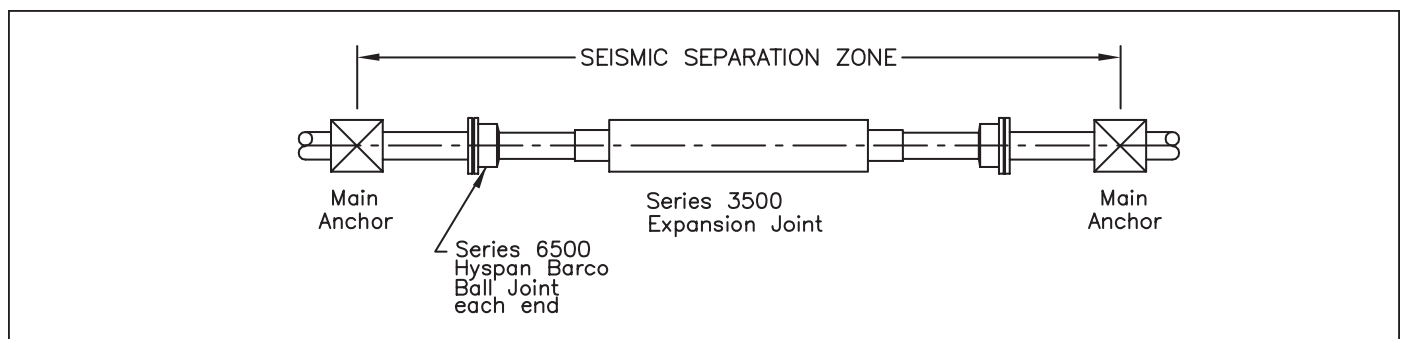

## Travel Required

The axial expansion or contraction of pipe is determined by the change in temperature. In order to select the correct travel refer to Table 1 which includes tabulated values of linear change in inches per 100 feet of pipe run for steel and stainless steel pipe. The values are based on an installation temperature of 70°F.

$$\text{Thermal Expansion or contraction (inches)} = \text{Length of run between anchors (feet)} \times \text{Linear change from Table 1} \div 100$$

During installation if the temperature is substantially different from 70°F it may be necessary to preset the expansion joint. Refer to Installation Preset in the Installation Procedure on Pages 14 and 15 to determine the preset required.

## Anchor Forces

Piping systems incorporating Type 3501-3506 expansion joints must include structural reactions or main anchors as shown in the application diagrams that are sufficient to withstand the full pressure thrust based on the effective area of the expansion joint, and the spring force produced by the deflection of the bellows.

$$\text{Main Anchor Force (lbs.)} = \text{Pressure Force Table 2 (lbs)} + \left\{ \text{Spring Rate (lb./in.) Column 2, Tables 5-8} \times \text{Axial Travel (inches)} \right\}$$

The pressure force must be based on the highest pressure anticipated during service and testing.

Piping systems incorporating dual anchor base expansion joints (3505 & 3506) multiple single joints (3501 & 3502) in long runs, and pressure balanced joints (3501PB & 3502PB) must include structural reactions or intermediate anchors as shown in the application diagrams. Intermediate anchors react the force produced by the bellows spring constant.

$$\text{Intermediate Anchor Force (lbs.)} = \left\{ \text{Spring Rate (lb./in.) Column 2 Tables 5-8} \right\} \times \left\{ \text{Axial Travel (inches)} \right\}$$

**Table 1 Thermal Expansion of Pipe per 100 feet**

Linear thermal expansion of pipe per 100 feet between 70°F and the tabulated temperature.

Saturated Vacuum (Hg)	Pressure (psig)	Temperature		Carbon Steel Pipe	Austenitic Stainless Steel
		°F	°C		
		-50	-46	-0.84	-1.24
		0	-18	-0.49	-0.72
		25	-4	-0.32	-0.46
29.7		32	0	-0.27	-0.40
29.6		50	10	-0.14	-0.21
29.2		70	21	0	0
28.0		100	38	0.23	0.34
26.0		125	52	0.42	0.62
22.4		150	66	0.61	0.90
16.3		175	80	0.80	1.18
6.0		200	93	0.99	1.46
0		212	100	1.10	1.60
	4	225	107	1.21	1.75
	5	250	121	1.40	2.03
	31	275	135	1.61	2.32
	52	300	149	1.82	2.61
	82	325	163	2.04	2.90
	120	350	177	2.26	3.20
	169	375	191	2.48	3.50
	232	400	205	2.70	3.80
	311	425	219	2.93	4.10
	407	450	232	3.16	4.41
	525	475	246	3.39	4.71
	664	500	260	3.62	5.01
1	2	3	4	5	6



**Table 2**  
**Pressure and Force Data/Series 3500 Externally Pressurized Expansion Joints**

Nominal Size (NPS)	Effective Area (square inches)	Tabulated Force (pounds) for Individual Pressure						
		50 psig	100 psig	150 psig	200 psig	250 psig	300 psig	450 psig
2	8.2	408	817	1225	1633	2042	2451	3690
2 1/2	10.6	533	1067	1599	2133	2666	3200	4770
3	13.7	685	1369	2054	2738	3423	4107	6165
4	22.7	1135	2269	3404	4538	5673	6807	10215
5	35.3	1763	3526	5288	7051	8814	10577	15885
6	50.3	2513	5027	7540	10053	12566	15080	22635
8	80.5	4026	8052	12077	16103	20129	24155	36225
10	115	5773	11547	17320	23093	28867	34640	54750
12	164	8228	16456	24684	32912	41140	49368	73800
14	206	10300	20599	30899	41199	51498	61798	92700
16	258	12901	25802	38702	51603	64504	77405	116100
18	318	15905	31810	47715	63620	79525	95430	143100
20	390	19529	39057	58586	78114	97643	117171	175500
24	541	27059	54119	81178	108238	135297	162357	243450
1	2	3	4	5	6	7	8	9

**Table 3**  
**Intermediate Pipe Guide Spacing /Series 3500 Externally Pressurized Expansion Joints**

Nominal Size (NPS)	150 psig Design (See pages 8 & 9)			300 psig Design (See pages 10 & 11)				
	System Pressure (psig)			System Pressure (psig)				
	50	100	150	50	100	150	200	300
2	24	18	15	21	17	14	13	11
2 1/2	29	23	19	26	21	18	16	14
3	38	29	25	31	26	22	20	17
4	46	35	29	39	31	27	24	21
5	48	38	33	41	34	30	27	23
6	58	45	38	50	41	36	32	27
8	78	60	50	70	56	47	42	35
10	100	75	63	90	71	60	53	44
12	115	85	70	103	80	67	59	49
14	108	83	70	99	79	67	60	50
16	121	92	77	112	88	75	66	55
18	132	100	84	123	96	81	72	60
20	146	109	90	127	100	85	75	63
24	167	123	102	147	114	97	86	71
1	2	3	4	5	6	7	8	9

**Note:**

- (1) The values listed are the center to center distance measured in feet.
- (2) Pipe guide spacing is a function of the expansion joint spring rate and effective area. The tabulated values are for Series 3500 expansion joints at the system design pressure listed.
- (3) The pressures listed are design values. Guide spacing has been calculated for the test pressure (1.5 X design).
- (4) Refer to Catalog 1004 for complete details on Hyspan Series 9500 Pipe Guides and their application.

## Materials of Construction and Dimensional Data

The following materials and specifications are used in the construction of all standard Series 3500 expansion joints.

**Flanges:** Flat face carbon steel made from ASME A-36 plate. Outside diameter and drilling per ASME/ANSI B16.5. 150 lb. drilling for all 150 psig designs, 300 lb. drilling for all 300 psig designs.

**Pipe:** Fixed and traveling pipe nipples and housing made from ASME A53 Grade B standard weight steel pipe. Weld end preparation per ASME/ANSI B16.9. Grooved ends per ANSI/AWWA C606-87.

**Guide Rings:** Steel plate per ASME A-36.

**Drain Port & Plug:** 3000 lb. thread-o-let made from ASME A105 steel forging.

**Bellows:** Three or four ply laminated

made from ASTM A240 type 321 stainless steel.

The Dimensional Data in Table 4 relates to the standard designs in Tables 5 through 10.

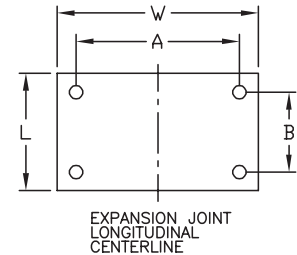

**Table 4**  
**Dimensional Data**

Nom Size (NPS)	Housing Outside Diameter (inches)		Centerline Height (inches) 3501AB, 3502AB 3505, 3506	Drain Port Size (NPS)	Anchor Base Pattern 3501AB, 3502AB, 3505, 3506				
	Part No. 3501, 3502 3505, 3506	Part No. 3501PB 3502PB			Hole Diameter (inches)	Base Length (L) (inches)	Base Width (W) (inches)	Hole Spacing (inches)	
								A	B
2	4.50		3.88	1/2	0.625	6.0	7.0	5.0	4.0
2 1/2	5.56		4.88	1/2	0.625	6.0	7.0	5.0	4.0
3	6.63		4.88	1/2	0.625	6.0	7.5	5.5	4.0
4	8.63	10.75	5.50	1/2	0.625	6.0	9.5	7.5	4.0
5	8.63	12.75	6.50	1/2	0.625	6.0	9.5	7.5	4.0
6	10.75	14.00	6.50	3/4	0.875	8.0	12.0	10.0	6.0
8	12.75	18.00	8.50	3/4	0.875	8.0	12.0	10.0	6.0
10	16.00	20.00	9.75	3/4	0.875	10.0	16.0	14.0	8.0
12	18.00	24.00	12.00	3/4	0.875	10.0	18.0	16.0	8.0
14	20.00	26.00	12.00	3/4	0.875	10.0	20.0	18.0	8.0
16	22.00	29.00	13.50	1	1.125	12.5	22.0	18.0	10.0
18	24.00	32.00	14.75	1	1.125	12.5	24.0	18.0	10.0
20	26.00	35.00	16.00	1	1.125	16.5	26.0	22.0	14.0
24	29.25	40.50	18.75	1	1.125	16.5	26.0	22.0	14.0
1	2	3	4	5	6	7	8	9	10

## Ordering Instructions

Refer to Tables 5 through 10 to select the configuration and service conditions required for your application. If the travel required is unknown, see the method of calculation on Page 5.

**Example** Single Expansion Joint  
Steel pipe weld ends  
150 psig at 500°F maximum  
4.0" axial travel maximum  
2" NPS

3502-131-4  
 ↑ Axial travel, 4.0" compression, 1.0" extension  
 ↑ Size & pressure designation, 2" NPS, 150 PSIG  
 ↑ Type specification, steel pipe weld end both ends, steel housing and guides

Single expansion joints, 3501 and 3502, ordered with anchor based are identified as 3501AB and 3502AB. Anchor bases are standard on dual anchor base joints, 3505 and 3506, and do not require the AB suffix. In-line pressure balanced joints are available as single configurations and identified as 3501PB and 3502PB—refer to Pages 12 & 13.

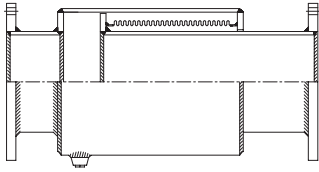
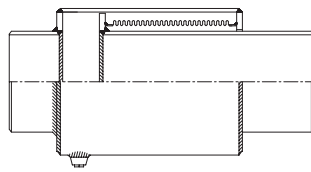
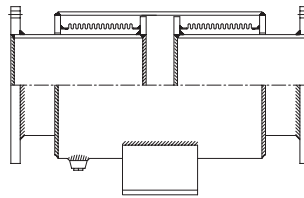
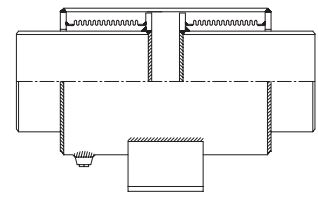
**3501 Fixed Flange**

**3502 Weld End**

**3505 Fixed Flange  
Dual Anchor Base**

**3506 Weld End  
Dual Anchor Base**

**Table 5 Type 3501 and 3502**
**Design Pressure: 150 psig Test Pressure: 225 psig Design Temperature: 500°F**

Nominal Size (NPS)	Axial Spring Rate (1) (lb/in)	Part Number 3501 3502 3503	Axial Compr. (inches)	Axial Ext. (inches)	3501		3502	
					Overall Length (inches)	Weight (lbs)	Overall Length (inches)	Weight (lbs)
2	33	-131-4	4	1	24.75	31	24.25	23
	22	-131-6	6	2	33.75	40	33.25	32
	17	-131-8	8	2	40.25	47	39.75	39
2 1/2	79	-135-4	4	1	24.75	44	24.13	33
	54	-135-6	6	2	33.75	56	33.13	46
	35	-135-8	8	2	40.25	65	39.63	54
3	66	-140-4	4	1	24.75	60	24.13	46
	40	-140-6	6	2	33.75	77	33.13	63
	31	-140-8	8	2	40.25	87	39.63	74
4	121	-148-4	4	1	24.75	89	24.13	70
	74	-148-6	6	2	33.75	114	33.13	95
	57	-148-8	8	2	40.25	131	39.63	112
5	313	-155-4	4	1	24.75	95	24.13	73
	196	-155-6	6	2	33.75	119	33.13	98
	139	-155-8	8	2	40.25	139	39.63	118
6	348	-160-4	4	1	26.50	141	25.88	110
	218	-160-6	6	2	35.25	174	34.63	142
	155	-160-8	8	2	41.75	202	41.13	171
8	380	-167-4	4	1	26.50	190	25.75	145
	234	-167-6	6	2	35.25	242	34.50	196
	176	-167-8	8	2	41.75	275	41.00	230
10	452	-174-4	4	1	26.50	259	25.75	202
	267	-174-6	6	2	35.25	326	34.50	268
	203	-174-8	8	2	41.75	370	41.00	313
12	418	-180-4	4	1	28.75	344	28.00	261
	253	-180-6	6	2	37.25	428	36.50	345
	183	-180-8	8	2	44.50	478	43.75	395
14	1193	-181-4	4	1	28.75	429	28.00	301
	738	-181-6	6	2	37.25	516	36.50	388
	515	-181-8	8	2	44.50	584	43.75	456
16	1314	-182-4	4	1	28.75	492	28.00	338
	813	-182-6	6	2	37.25	589	36.50	436
	567	-182-8	8	2	44.50	666	43.75	512
18	1438	-183-4	4	1	29.50	528	28.75	374
	888	-183-6	6	2	38.00	636	37.25	482
	619	-183-8	8	2	45.25	721	44.50	567
20	1206	-184-4	4	1	29.50	596	28.75	415
	748	-184-6	6	2	38.00	717	37.25	536
	529	-184-8	8	2	45.25	811	44.50	631
24	1409	-186-4	4	1	29.50	742	28.75	468
	874	-186-6	6	2	38.00	883	37.25	609
	616	-186-8	8	2	45.25	993	44.50	719
1	2	3	4	5	6	7	8	9



**Table 6 Type 3505 and 3506**

**Design Pressure: 150 psig Test Pressure: 225 psig Design Temperature: 500°F**

Nominal Size (NPS)	Axial Spring Rate (1) (lb/in)	Part Number 3505 3506	Total Axial Compr. (2) (inches)	Total Axial Ext. (2) (inches)	3505		3506	
					Overall Length (inches)	Weight (lbs)	Overall Length (inches)	Weight (lbs)
2	33	-131-8	8	2	42.00	56	41.50	49
	22	-131-12	12	4	60.00	75	59.50	66
	17	-131-16	16	4	73.00	87	72.50	79
2 1/2	79	-135-8	8	2	41.75	77	41.13	66
	54	-135-12	12	4	59.75	102	59.13	90
	35	-135-16	16	4	72.75	119	72.13	108
3	66	-140-8	8	2	41.75	104	41.13	89
	40	-140-12	12	4	59.75	137	59.13	123
	31	-140-16	16	4	72.75	158	72.13	144
4	121	-148-8	8	2	41.75	151	41.13	132
	74	-148-12	12	4	59.75	202	59.13	181
	57	-148-16	16	4	72.75	235	72.13	215
5	313	-155-8	8	2	41.75	161	41.13	139
	196	-155-12	12	4	59.75	209	59.13	187
	139	-155-16	16	4	72.75	251	72.13	229
6	348	-160-8	8	2	44.25	246	43.63	212
	218	-160-12	12	4	61.75	311	61.13	277
	155	-160-16	16	4	74.75	368	74.13	334
8	380	-167-8	8	2	44.00	323	43.25	274
	234	-167-12	12	4	61.50	425	60.75	376
	176	-167-16	16	4	74.50	493	73.75	444
10	452	-174-8	8	2	43.00	445	42.25	382
	267	-174-12	12	4	60.50	578	59.75	516
	203	-174-16	16	4	73.50	667	72.75	604
12	418	-180-8	8	2	47.50	588	46.75	490
	253	-180-12	12	4	64.50	755	63.75	661
	183	-180-16	16	4	79.00	853	78.25	759
14	1193	-181-8	8	2	46.25	699	45.50	558
	738	-181-12	12	4	63.25	875	62.50	734
	515	-181-16	16	4	77.75	1009	77.00	870
16	1314	-182-8	8	2	46.25	822	45.50	654
	813	-182-12	12	4	63.25	1020	62.50	852
	567	-182-16	16	4	77.75	1170	77.00	1004
18	1438	-183-8	8	2	47.75	900	47.00	721
	888	-183-12	12	4	64.75	1116	64.00	941
	619	-183-16	16	4	79.25	1286	78.50	1109
20	1206	-184-8	8	2	47.75	1047	47.00	838
	748	-184-12	12	4	64.75	1288	64.00	1083
	529	-184-16	16	4	79.25	1477	78.50	1270
24	1409	-186-8	8	2	47.75	1241	47.00	934
	874	-186-12	12	4	64.75	1523	64.00	1219
	616	-186-16	16	4	79.25	1743	78.50	1436
1	2	3	4	5	6	7	8	9

**Note:**

- (1) Force per inch of compression resulting from the bellows spring constant. Refer to Table 2 for pressure thrust force.
- (2) For Type 3505 and 3506 travel stated is the total. Travel each side of the anchor is 1/2 the tabulated value.
- (3) Refer to Table 4 for housing outside diameter, drain port size and anchor base details and centerline height of anchor base models.

**3501 Fixed Flange**

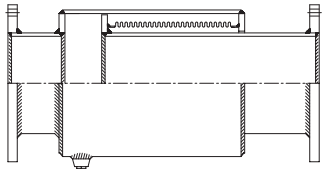

**3502 Weld End**

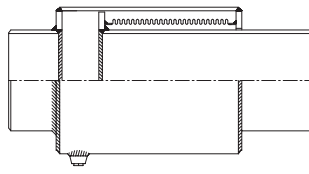

**3505 Fixed Flange  
Dual Anchor Base**

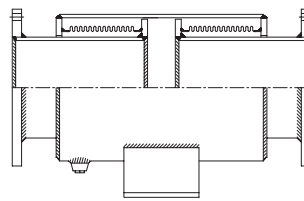

**3506 Weld End  
Dual Anchor Base**

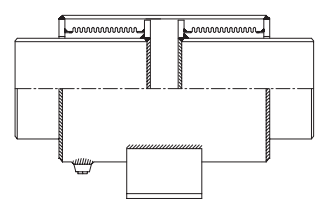

**Table 7 Type 3501 and 3502**

**Design Pressure: 300 psig Test Pressure: 450 psig Design Temperature: 500°F**

Nominal Size (NPS)	Axial Spring Rate (1) (lb/in)	Part Number 3501 3502	Axial Compr. (inches)	Axial Ext. (inches)	3501		3502	
					Overall Length (inches)	Weight (lbs)	Overall Length (inches)	Weight (lbs)
2	68	-331-4	4	1	24.75	35	24.25	24
	47	-331-6	6	2	33.75	44	33.25	34
	35	-331-8	8	2	40.25	51	39.75	41
2 1/2	137	-335-4	4	1	24.75	48	24.13	32
	93	-335-6	6	2	33.75	61	33.13	47
	59	-335-8	8	2	40.25	70	39.63	56
3	195	-340-4	4	1	24.75	70	24.13	48
	117	-340-6	6	2	33.75	88	33.13	66
	85	-340-8	8	2	40.25	99	39.63	77
4	293	-348-4	4	1	24.75	105	24.13	72
	177	-348-6	6	2	33.75	131	33.13	98
	135	-348-8	8	2	40.25	149	39.63	115
5	606	-355-4	4	1	24.75	113	24.13	75
	377	-355-6	6	2	33.75	138	33.13	100
	263	-355-8	8	2	40.25	160	39.63	122
6	685	-360-4	4	1	26.50	175	25.88	111
	426	-360-6	6	2	35.25	208	34.63	145
	297	-360-8	8	2	41.75	238	41.13	175
8	745	-367-4	4	1	26.50	229	25.75	148
	457	-367-6	6	2	35.25	283	34.50	202
	340	-367-8	8	2	41.75	318	41.00	236
10	892	-374-4	4	1	26.50	307	25.75	205
	516	-374-6	6	2	35.25	376	34.50	275
	389	-374-8	8	2	41.75	421	41.00	320
12	1045	-380-4	4	1	28.75	434	28.00	267
	628	-380-6	6	2	37.25	523	36.50	355
	441	-380-8	8	2	44.50	573	43.75	406
14	1879	-381-4	4	1	28.75	522	28.00	308
	1157	-381-6	6	2	37.25	614	36.50	398
	794	-381-8	8	2	44.50	684	43.75	469
16	2073	-382-4	4	1	28.75	598	28.00	345
	1275	-382-6	6	2	37.25	701	36.50	447
	874	-382-8	8	2	44.50	779	43.75	527
18	2503	-383-4	4	1	29.50	727	28.75	340
	1535	-383-6	6	2	38.00	840	37.25	495
	1046	-383-8	8	2	45.25	930	44.50	583
20	3283	-384-4	4	1	29.50	891	28.75	435
	2014	-384-6	6	2	38.00	1023	37.25	566
	1373	-384-8	8	2	45.25	1128	44.50	670
24	3860	-386-4	4	1	29.50	1106	28.75	492
	2368	-386-6	6	2	38.00	1259	37.25	645
	1611	-386-8	8	2	45.25	1382	44.50	766
1	2	3	4	5	6	7	8	9

**Table 8 Type 3505 and 3506**

**Design Pressure: 300 psig Test Pressure: 450 psig Design: Temperature 500°F**

Nominal Size (NPS)	Axial Spring Rate (1) (lb/in)	Part Number 3505 3506	Total Axial Compr. (2) (inches)	Total Axial Ext. (2) (inches)	3505		3506	
					Overall Length (inches)	Weight (lbs)	Overall Length (inches)	Weight (lbs)
2	68	-331-8	8	2	42.00	58	41.50	50
	47	-331-12	12	4	60.00	79	59.50	68
	35	-331-16	16	4	73.00	93	72.50	81
2 1/2	137	-335-8	8	2	41.75	82	41.13	67
	93	-335-12	12	4	59.75	107	59.13	92
	59	-335-16	16	4	72.75	125	72.13	110
3	195	-340-8	8	2	41.75	115	41.13	92
	117	-340-12	12	4	59.75	150	59.13	127
	85	-340-16	16	4	72.75	172	72.13	149
4	293	-348-8	8	2	41.75	169	41.13	136
	177	-348-12	12	4	59.75	221	59.13	186
	135	-348-16	16	4	72.75	236	72.13	222
5	606	-355-8	8	2	41.75	182	41.13	143
	377	-355-12	12	4	59.75	231	59.13	192
	263	-355-16	16	4	72.75	275	72.13	236
6	685	-360-8	8	2	44.25	280	43.63	216
	426	-360-12	12	4	61.75	347	61.13	283
	297	-360-16	16	4	74.75	406	74.13	342
8	745	-367-8	8	2	44.00	364	43.25	280
	457	-367-12	12	4	61.50	471	60.75	387
	340	-367-16	16	4	74.50	540	73.75	456
10	892	-374-8	8	2	43.00	494	42.25	388
	516	-374-12	12	4	60.50	633	59.75	527
	389	-374-16	16	4	73.50	724	72.75	619
12	1045	-380-8	8	2	47.50	679	46.75	503
	628	-380-12	12	4	64.50	852	63.75	681
	441	-380-16	16	4	79.00	954	78.25	783
14	1879	-381-8	8	2	46.25	792	45.50	571
	1157	-381-12	12	4	63.25	976	62.50	755
	794	-381-16	16	4	77.75	1115	77.00	896
16	2073	-382-8	8	2	46.25	929	45.50	669
	1275	-382-12	12	4	63.25	1135	62.50	875
	874	-382-16	16	4	77.75	1292	77.00	1034
18	2503	-383-8	8	2	47.75	1180	47.00	738
	1535	-383-12	12	4	64.75	1320	64.00	967
	1046	-383-16	16	4	79.25	1500	78.50	1142
20	3283	-384-8	8	2	47.75	1348	47.00	878
	2014	-384-12	12	4	64.75	1610	64.00	1144
	1373	-384-16	16	4	79.25	1820	78.50	1349
24	3860	-386-8	8	2	47.75	1612	47.00	981
	2368	-386-12	12	4	64.75	1918	64.00	1292
	1611	-386-16	16	4	79.25	2071	78.50	1529
1	2	3	4	5	6	7	8	9

**Note:**

- (1) Force per inch of compression resulting from the bellows spring constant. Refer to Table 2 for pressure thrust force.
- (2) For Type 3505 and 3506 travel stated is the total. Travel each side of the anchor is 1/2 the tabulated value.
- (3) Refer to Table 4 for housing outside diameter, drain port size and anchor base details and centerline height of anchor base models.

## Series 3500

### In-Line Externally Pressurized Pressure Balanced Expansion Joints

Series 3500 In-Line Pressure balanced expansion joints provide the same benefits as the standard design with the added advantage of internally reacting the pressure thrust by linking an additional bellows designed with twice the effective area of the expansion bellows. The design eliminates the requirement for main anchors to react the pressure thrust—only intermediate anchors must be provided to restrain the bellows spring force. Technical data is provided in Tables 9 and 10 for sizes 4" through 24".

3501PB Fixed Flange

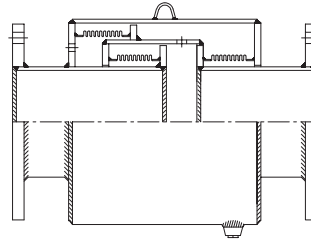

3502PB Weld End

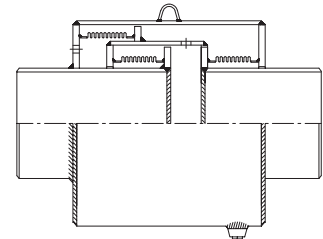

**Table 9 Type 3501PB & 3502PB**

**Design Pressure: 150 psig Test Pressure: 225 psig Design Temperature: 500°F**

Nominal Size (NPS)	Axial Spring Rate (1) (lb/in)	Part Number 3501PB 3502PB	Axial Compr. (inches)	Axial Ext. (inches)	3501PB		3502PB	
					Overall Length (inches)	Weight (lbs)	Overall Length (inches)	Weight (lbs)
4	638	-148-4	4	1	41.0	218	39.0	196
	408	-148-6	6	2	57.0	296	55.0	274
	320	-148-8	8	2	68.0	349	66.0	328
5	885	-155-4	4	1	41.0	278	39.0	255
	576	-155-6	6	2	57.0	264	55.0	339
	473	-155-8	8	2	68.0	441	66.0	417
6	1056	-160-4	4	1	43.0	336	39.0	302
	688	-160-6	6	2	59.0	436	55.0	400
	569	-160-8	8	2	70.0	528	66.0	492
8	1577	-167-4	4	1	43.0	488	39.0	437
	1014	-167-6	6	2	59.0	656	55.0	605
	786	-167-8	8	2	70.0	766	66.0	715
10	1930	-174-4	4	1	43.0	587	40.0	521
	1241	-174-6	6	2	59.0	776	56.0	720
	965	-174-8	8	2	70.0	916	67.0	850
12	2822	-180-4	4	1	48.0	798	42.0	705
	1796	-180-6	6	2	64.0	1055	57.0	962
	1518	-180-8	8	2	75.0	1212	69.0	1109
14	4726	-181-4	4	1	48.0	939	42.0	794
	3038	-181-6	6	2	64.0	1197	57.0	1053
	2363	-181-8	8	2	75.0	1405	69.0	1260
16	5116	-182-4	4	1	48.0	1097	42.0	922
	3289	-182-6	6	2	64.0	1386	57.0	1221
	2558	-182-8	8	2	75.0	1613	69.0	1438
18	5766	-183-4	4	1	49.0	1191	42.0	1013
	3706	-183-6	6	2	64.0	1518	57.0	1341
	2882	-183-8	8	2	76.0	1771	69.0	1597
20	5040	-184-4	4	1	49.0	1340	42.0	1130
	3241	-184-6	6	2	64.0	1699	57.0	1489
	2520	-184-8	8	2	76.0	1978	69.0	1768
24	5674	-186-4	4	1	50.0	1559	42.0	1285
	3648	-186-6	6	2	65.0	1980	57.0	1706
	2837	-186-8	8	2	77.0	2306	69.0	1928
1	2	3	4	5	6	7	8	9

**Table 10 Type 3501PB & 3502PB**

**Design Pressure: 300 psig Test Pressure: 450 psig Design Temperature: 500°F**

Nominal Size (NPS)	Axial Spring Rate (1) (lb/in)	Part Number 3501PB 3502PB	Axial Compr. (inches)	Axial Ext. (inches)	3501PB		3502PB	
					Overall Length (inches)	Weight (lbs)	Overall Length (inches)	Weight (lbs)
4	1467	-348-4	4	1	42.0	232	39.0	200
	886	-348-6	6	2	58.0	314	55.0	282
	675	-348-8	8	2	69.0	368	66.0	336
5	3028	-355-4	4	1	42.0	297	39.0	261
	1884	-355-6	6	2	58.0	387	55.0	350
	1314	-355-8	8	2	69.0	467	66.0	430
6	3424	-360-4	4	1	44.5	367	39.0	310
	2132	-360-6	6	2	60.5	470	55.0	413
	1483	-360-8	8	2	70.5	557	66.0	500
8	3725	-367-4	4	1	44.5	526	39.0	450
	2285	-367-6	6	2	60.5	701	55.0	625
	1699	-367-8	8	2	70.5	818	66.0	742
10	4458	-374-4	4	1	44.5	634	40.0	540
	2580	-374-6	6	2	60.5	854	56.0	760
	1947	-374-8	8	2	70.5	980	67.0	886
12	5223	-380-4	4	1	46.5	880	42.0	726
	3139	-380-6	6	2	63.0	1151	57.0	997
	2205	-380-8	8	2	73.0	1307	69.0	1153
14	9397	-381-4	4	1	50.0	1015	42.0	815
	5783	-381-6	6	2	65.0	1288	57.0	1088
	3968	-381-8	8	2	77.5	1504	69.0	1309
16	10367	-382-4	4	1	50.0	1170	42.0	935
	6373	-382-6	6	2	65.0	1482	57.0	1247
	4369	-382-8	8	2	77.5	1728	69.0	1493
18	12515	-383-4	4	1	50.0	1359	42.0	1040
	7677	-383-6	6	2	65.0	1701	57.0	1382
	5229	-383-8	8	2	77.5	1971	69.0	1652
20	16414	-384-4	4	1	51.5	1621	42.0	1195
	10072	-384-6	6	2	66.5	2016	57.0	1590
	6864	-384-8	8	2	79.0	2338	69.0	1912
24	19300	-386-4	4	1	51.5	1940	42.0	1363
	11840	-386-6	6	2	66.5	2408	57.0	1831
	8057	-386-8	8	2	79.0	2716	69.0	2159
1	2	3	4	5	6	7	8	9

**Note:**

- (1) Force (lbs.) per inch of compression (pipe expansion) resulting from bellows spring constant.
- (2) Refer to Table 4 on Page 7 for housing outside diameter and drain port size.
- (3) Refer to Applications on page 4 for correct installation.
- (4) The anchor force is calculated as follows:

$$\text{Anchor Force (lbs.)} = \left\{ \begin{array}{l} \text{Spring Rate (lb./in.)} \\ \text{Column 2 Tables 9 \& 10} \end{array} \right\} \times \left\{ \begin{array}{l} \text{Axial Travel} \\ \text{(inches)} \end{array} \right\}$$



## Installation Procedure

**Application:** Series 3500 Externally Pressurized Expansion Joints are designed for applications where the principal motion is axial to the centerline of the expansion joint, and the system includes guides, supports and anchors sufficient to restrain the piping at the service and test conditions. Steam systems must include adequate traps to remove condensate. Liquid systems must include surge compensation.

**Operating Conditions:** Series 3500 expansion joints are supplied with a tag attached stating the Part Number and Design Pressure. Standard designs are 150 psig and 300 psig, and the test pressures are 225 psig and 450 psig respectively. The design temperature for all standard joints is 500°F. Be certain that the system conditions and test conditions do not exceed the design values.

**Movement:** The axial travel of the joint is included in the part number as the last digit(s) i.e. P/N 3501-148-4 is designed for 4" axial travel (compression). Consult the purchase specification to confirm the correct part number and location in the system. Refer to Travel Required on Page 5 for the method of calculating pipe expansion or contraction.

**Flow Direction and Orientation:** The flow direction can be either direction for Series 3500 expansion joints. Be certain that the free end is attached to the pipe that expands on single joints (3501AB & 3502AB) with an anchor base. The drain port must be at the bottom of the joint for horizontal and vertical installations.

**Media & Environment:** Series 3500 expansion joints are designed for properly maintained steam, hot water and chilled water systems. They can be used for other media that are compatible with the materials of construction. Refer to Material Specifications on Page 7 for the materials used for standard construction. Be certain that the exterior of the expansion joint is not exposed to corrosive substances such as minerals in ground water and road salt.

**Guides, Supports, Anchors:** Series 3500 expansion joints are designed for applications where the principal movement is axial to the centerline of the expansion joint, and the system includes guides, supports and anchors. Refer to Applications on Pages 3 and 4 for system requirements. Refer to Hyspan Series 9500 Catalog 1004 for pipe guide design information.

**Anchor Base:** Type 3505 and 3506 dual expansion joints include an intermediate anchor base to ensure that the bellows element on each side of the base absorbs the motion on one side. Refer to intermediate anchor forces in the Anchor Forces section on Page 5 for force required.

Single expansion joints, types 3501 and 3502, are available with an anchor base designed as a main anchor. Refer to main anchor forces in the Anchor Forces section on page 5 for force required. The anchor base height and base pattern for both configurations are given in Table 4, page 7.

*CAUTION: The structure attached to the anchor base must be capable of restraining the thrust forces and moments developed by the expansion joint.*

**Shipping Restraints:** External restraints are installed at the factory to insure installation at the correct length and alignment. They are painted yellow and labeled—Shipping Bars, Remove after Installation. Leave these restraints installed until after the installation of the expansion joint is complete—but they must be removed prior to pressure testing. *CAUTION: Shipping Bars are not designed to react the pressure thrust of the expansion joint—they must be removed prior to testing. Normally the shipping restraints are installed by welding—remove by cutting and grinding welds flush.*

Standard expansion joints are factory set for the travel tabulated in this catalog. The principal travel is axial compression (pipe expansion) with allowance for extension if the pipe temperature is reduced below the installation temperature. Refer to the purchase specifications for joints ordered with special settings.

### Post Installation Inspection

1. Inspect the expansion joint for damage.
2. Are the Shipping Restraints removed?
3. Is the joint free to move and is the pipe supported and guided to ensure that the pipe motion is axial to the expansion joint?
4. Is the expansion joint installed at the correct location and are the anchors, guides and supports installed in accordance with the system design?
5. Are the guides and supports free to allow the movement of the expansion joint?
6. Is the supporting structure for the anchor adequate to react the forces and moments?

### Installation Preset

Series 3500 expansion joints can be ordered from the factory with factory preset; however, if it is necessary to change the travel during installation, the shipping bars must be removed and the length adjusted. The following table is a tabulation of the thermal expansion or contraction for various pipe run lengths corresponding to temperature differences from 70° F.

For example, if the expansion joint is used as a replacement in a system that has not cooled down, and the pipe

temperature is 170°F over a 200 foot run, the joint must be compressed 1.53".

**Table 11 Installation Preset**

Temperature Difference °F	Distance Between Anchors – Feet					
	50	100	150	200	250	300
20	0.08	0.15	0.23	0.31	0.38	0.46
30	0.11	0.23	0.34	0.46	0.57	0.69
40	0.15	0.31	0.46	0.61	0.76	0.92
50	0.19	0.68	0.57	0.76	0.95	1.15
60	0.23	0.46	0.69	0.92	1.15	1.37
70	0.27	0.53	0.80	1.07	1.34	1.60
80	0.31	0.61	0.92	1.22	1.53	1.83
90	0.34	0.69	1.03	1.37	1.72	2.06
100	0.38	0.76	1.15	1.53	1.91	2.29
110	0.42	0.84	1.26	1.68	2.10	2.52
120	0.46	0.92	1.37	1.83	2.29	2.75
140	0.53	1.07	1.60	2.14	2.67	3.20
160	0.61	1.22	1.83	2.44	3.05	3.66
180	0.69	1.37	2.06	2.75	3.43	4.12
200	0.76	1.53	2.29	3.05	3.82	4.57
1	2	3	4	5	6	7

Field preset is not recommended unless it cannot be avoided. Note that there must be a significant temperature difference to warrant presetting during installation. If presetting is

anticipated, Series 3500 expansion joints can be ordered with threaded adjusting rods factory installed to facilitate presetting.

**FIVE YEAR LIMITED WARRANTY**

This warranty is given by HYSpan PRECISION PRODUCTS, INC. ("HYSpan") for the benefit of the first purchasers for use of its Series 3500 Externally Pressurized Expansion Joints manufactured by HYSpan to standard catalog construction or standard construction with laminated Alloy 625 bellows. The product is warranted to be free from defects in material and workmanship for a period of five (5) years from the date of shipment by HYSpan in accordance with the following conditions:

1. The design pressure and temperature are not exceeded—including surge and upset conditions.
2. The installation conforms to HYSpan installation instructions and approved practice for anchoring, supporting and guiding, and generally accepted good piping practice.
3. Substances in contact with all internal and external surfaces must be compatible with the materials of construction, including all contaminants. Steam, condensate, and water containing more than 100 parts per million chlorides, are specifically excluded when stainless bellows are used; Alloy 625 bellows construction qualifies.
4. The warranty shall be limited to the replacement by HYSpan of the same model Series 3500 expansion joint, and payment for transportation by the least expensive method. Labor, material and other costs related to the failure or replacement of the expansion joint are not included. HYSpan shall not be liable for damage or delay suffered by the purchaser regardless of whether such damages are general, special or consequential in nature, whether caused by defective material or workmanship, or whether caused by HYSpan's negligence regardless of the degree.
5. The warranty is put in force by receipt at the factory of a completed and executed Warranty Card, which is provided with each expansion joint.
6. The warranty is limited to installations in the United States, Puerto Rico and Canada.

The purchaser shall advise the HYSpan factory of any warranty claim, including the nature of the failure and the serial number of the expansion joint (permanently located adjacent to the lifting lug). HYSpan shall provide return goods authorization and shipping directions to return the failed joint to the factory. A mutually agreeable delivery schedule and method of shipping the replacement shall be established. The purchaser shall furnish a confirming purchase order and is obligated to the current replacement cost of the joint and shipping expense. Upon receipt of the failed product, the cause of failure shall be determined by the factory at no expense to the purchaser. A credit shall be issued by the factory for the replacement cost and least expensive shipping for valid warranty claims. In the event of a dispute, HYSpan shall furnish the failed product to the purchaser or their representative for failure analysis.



**Hyspan**<sup>®</sup>

Hyspan Precision Products, Inc.  
1685 Brandywine Avenue  
Chula Vista, CA 91911

Tel: (619) 421-1355  
Fax: (619) 421-1702  
[www.hyspan.com](http://www.hyspan.com)